

REMOVE ALL BURRS  
AND SHARP EDGES

IF IN DOUBT ASK

DRILL & TAP  
M10x1.5 THRU'  
TO BORE

2 - HOLES  
Ø27 THRU'

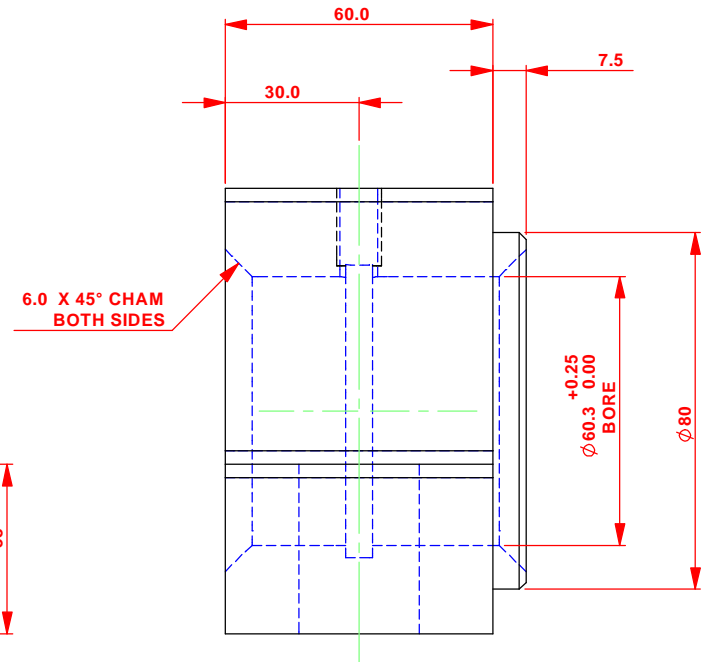
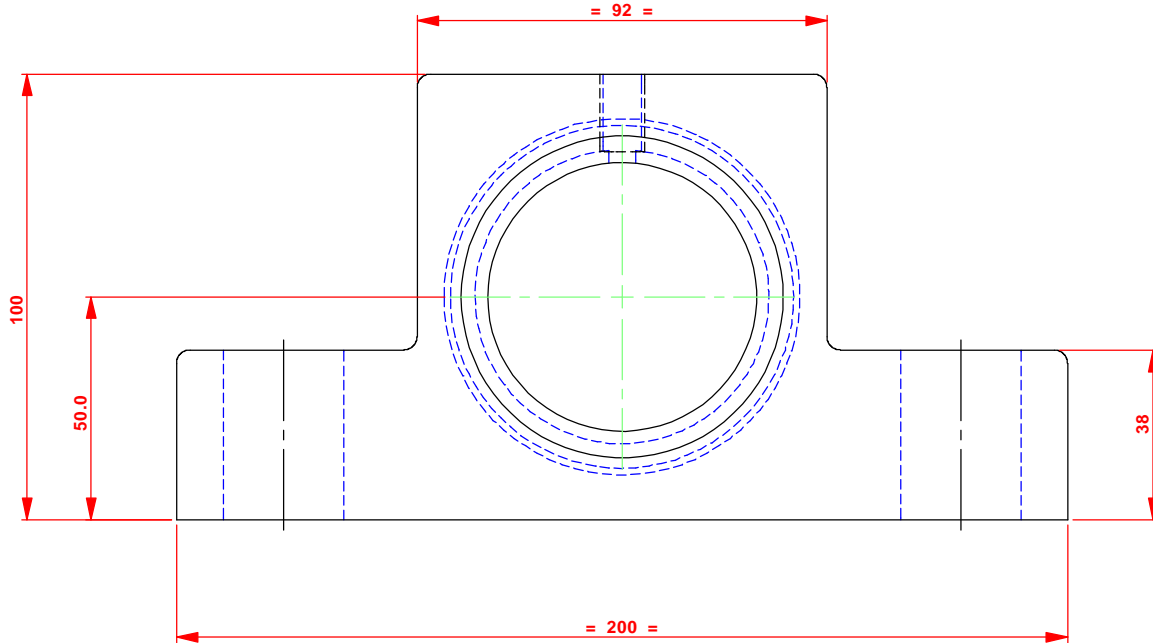
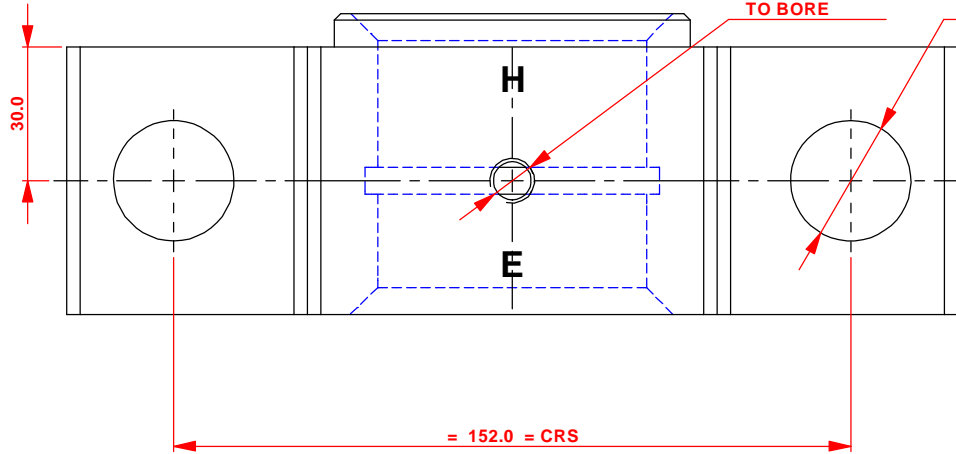

SUPPLIER NOTE:  
DISCARD DRG. AFTER  
MANUFACTURE



VISHAY PM ONBOARD LTD  
AIREDALE HOUSE  
CANAL ROAD  
BRADFORD  
BD2 1AG  
TEL: 44 (0)1274 771177  
FAX: 44 (0)1274 781178

THIS DRAWING/SPECIFICATION IS THE  
PROPERTY OF VISHAY PM ONBOARD LIMITED  
IT IS CONFIDENTIAL AND PROTECTED  
BY COPYRIGHT. IT MUST NOT BE LOANED  
COPIED, REPRODUCED OR COMMUNICATED  
EITHER WHOLLY OR IN PART TO A THIRD  
PARTY AND MUST NOT BE USED FOR ANY  
PURPOSE DETRIMENTAL TO THE INTERESTS  
OF VISHAY PM ONBOARD LIMITED WITHOUT  
THEIR WRITTEN PERMISSION.

3.2  
SURFACE FINISH  
UNLESS  
OTHERWISE STATED

TOLERANCES  
NO DEC. PLCS ± 0.25mm  
ONE DEC. PLC ± 0.10mm  
TWO DEC. PLCS ± 0.05mm  
ANGLES ± 2 DEG.

		PROJECT NAME: <b>UNDERBODY SYSTEMS</b>	
No OFF	XX	DATE: 08.10.09.	TITLE: <b>Ø 60 BORE TRUNNION (FOR EDBRO &amp; HYVA RAM)</b>
DRAWN:	G.C.	SCALE: 1:1.25	
MATERIAL: <b>SEE NOTE</b>		PAGES 1 OF 1	PART No. <b>197825</b>
		ALL DIMS IN MM UNLESS OTHERWISE STATED	DRAWING No. <b>197825</b>
		THIRD ANGLE PROJ.	REV. <b>D</b> A3